







INSTRUMENTS | DRILLS & TOOLS INDEX

SURGICAL STAINLES STEEL







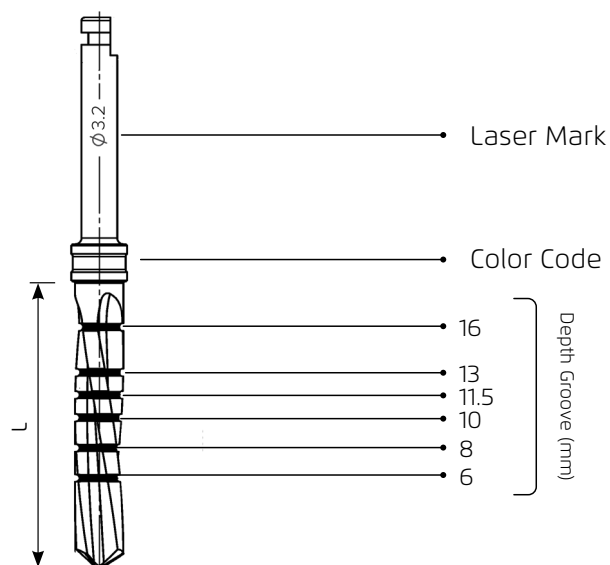

DRILLS COLOR CODE

Ø 2.0	
Ø 2.8	
Ø 3.2	
Ø 3.65	
Ø 4.2	
Ø 5.2	









INSTRUMENTS | DRILLS

STANDARD DRILLS

Ø D (mm)	L (mm)	REF. NO	
2.0	19	NMCD1220	
2.5		NMCD1225	
2.8		NMCD1228	
3.2		NMCD1232	
3.65		NMCD1236	
4.2		NMCD1242	
5.2		NMCD1252	

SHORT DRILLS







Ø D (mm)	L (mm)	REF. NO	
2.0	13	NM-D1420	
2.8		NM-D1428	
3.2		NM-D1432	
3.65		NM-D1436	
4.2		NM-D1442	
5.2		NM-D1452	

INSTRUMENTS | DRILLS







STEP DRILLS

Ø D (mm)	L (mm)	Ref. No	
2.8-3.2	19	NMSD4032	
3.2-3.65		NMSD4036	
3.65-4.2		NMSD4042	
4.2-5.2		NMSD4052	

CONICAL DRILLS

Ø D1-D2 (mm)	L (mm)	Ref. No	
1.8-2.4	19	NMCD3018	
2.0-3.2		NMCD3020	
2.5-3.7		NMCD3025	
2.7-4.0		NMCD3027	
2.7-4.5		NMCD3028	
3.1-5.5		NMCD3031	



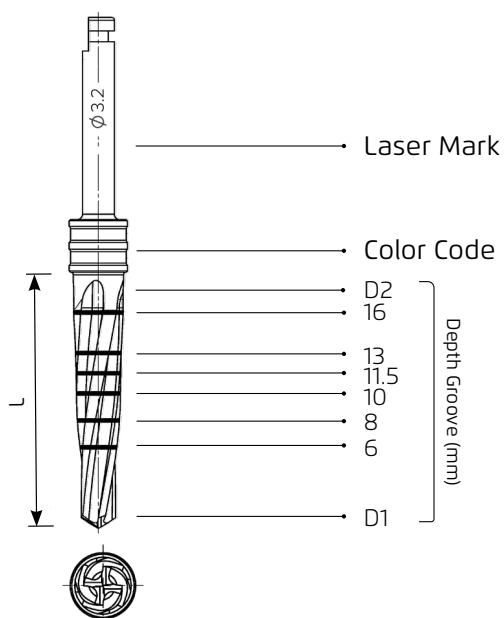

DRILLS COLOR CODE

Ø 1.8-2.4	
Ø 2.0-3.2	
Ø 2.5-3.7	
Ø 2.7-4.0	
Ø 2.7-4.5	
Ø 3.1-5.5	





INSTRUMENTS

BONE PROFILERS



BONE PROFILER MILL			
Ø D (mm)	Angle (°)	Ref. No	
4.0	90	NM-D3371	
5.0	30	NM-D3372	
6.5	45	NM-D3373	
GUIDED PIN FOR BONE PROFILER MILL			
Ø D (mm)		Ref. No	
2.4		NM-X3370	

TISSUE PUNCH

Ø D (mm)	Ref. No	
4.2	NM-D2642	
5.0	NM-D2650	

INSTRUMENTS | DRILLS

COUNTERSINK DRILLS

Ø D (mm)	Ref. No	
3.8-4.2	NMCD1034	
5.0-6.0	NMCD1056	



MARKING DRILL

Ø D (mm)	Ref. No	
1.9	NM-D3410	

NARROW DRILLS

Ø D (mm)	Ref. No	
1.2	NMCD2312	
1.5	NMCD2315	

TREPHINE DRILLS

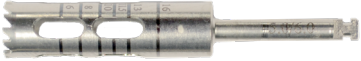
Ø D (mm)	Ref. No	
3.0-4.0	NM-D2030	
4.0-5.0	NM-D2040	
5.0-6.0	NM-D2050	

EXTENSION DRILL

Ø D (mm)	Ref. No	
-	NM-D3412	

BONE SCREW DRILL

Ø D (mm)	L (mm)	Ref. No	
1.2	28	NM-D2408	
1.2	32	NM-D2412	

INSTRUMENTS | ZYGOMATIC INSTRUMENTS

ZYGOMATIC STEP DRILLS

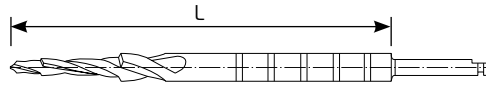

Ø D (mm)	L (mm)	Drill No.		Ref. No
2.0/2.5/3.0/4.2	40	1		NM-D7520
	50			NM-D7620
	60			NM-D7020
	80			NM-D7120
2.8/3.0/4.2	40	2		NM-D7528
	50			NM-D7628
	60			NM-D7028
	80			NM-D7128
2.8/3.2/4.2	40	3		NM-D7532
	50			NM-D7632
	60			NM-D7032
	80			NM-D7132

ZYGOMATIC BURS FOR GROOVE PREPARATION

Ø D (mm)	L (mm)			Ref. No
4.2	30	Fine Grit		NM-D7201
		Medium Grit		NM-D7202
		Coarse Grit		NM-D7203
		Diamond Ball Burr		NM-D7501

DEPTH PROBE NM-X1028

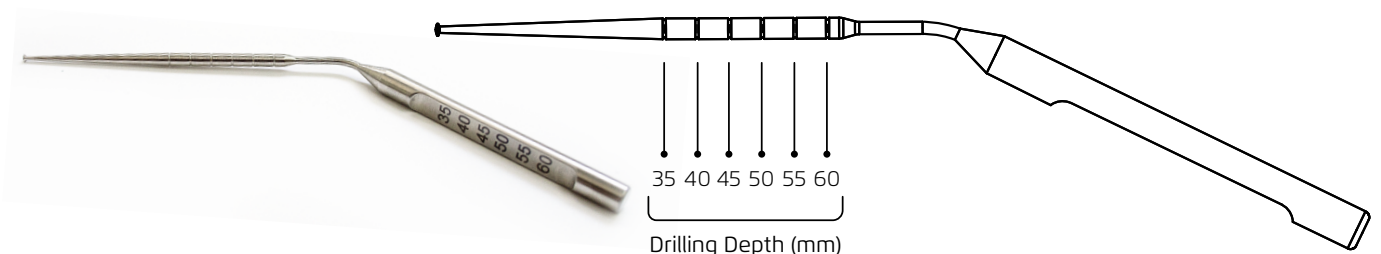





INSTRUMENTS | PTERYGOID INSTRUMENTS

LONG DRILLS

Ø D (mm)	L (mm)	REF. NO	
2.3	43	NM-D7423	
2.8	43	NM-D7428	
3.2	43	NM-D7432	
3.65	43	NM-D7436	

DRILLS COLOR CODE

Ø 2.3	
Ø 2.8	
Ø 3.2	
Ø 3.65	

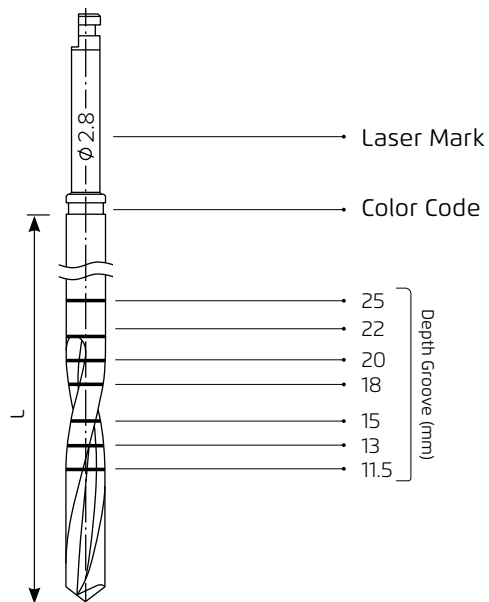

OSTEOTOMES

Ø D (mm)	Ref. No	
2.0	NM-X3001	
3.0	NM-X3002	